



Operator's Instruction Manual
MODEL# PH550(TXJ0550)

Parts Cart



This is the safety alert symbol. It is used to alert you to potential personal injury hazards. Obey all safety messages that follow this symbol to avoid possible injury or death.



Questions, problems, missing parts? Before returning to your retailer, call our customer service department at 1-888-448-6746, 8 a.m.- 5 p.m., PST, Monday-Friday.

⚠ SAFETY INFORMATION

Save these instructions. For your safety, read, understand, and follow the information provided with and on this product before using. The owner and/or operator of this equipment shall have an understanding of safe use/operating procedures before attempting to use. The owner and/or operator shall be aware that the use of this product may require special skills and knowledge. Instructions and safety information shall be conveyed in the operator's native language before use of this device is authorized. If any doubt exists as to the safe and proper use of this product as outlined in this factory authorized manual, remove from service immediately.

Inspect before each use. Do not use if broken, bent, cracked, or damaged parts (including labels) are noted. If the product appears damaged in any way, operates abnormally or is missing parts, it should be removed from service immediately and the manufacturer notified. If you suspect that the product was subjected to a shock load (a load suddenly dropped unexpectedly upon it), immediately discontinue use until product has been checked by a factory authorized service center (contact distributor or manufacturer for list of Authorized Service Centers). It is recommended that an annual inspection be done by qualified personnel. Labels and owner's manuals are available from manufacturer.

⚠ WARNING!

1. READ, STUDY AND UNDERSTAND ALL WARNINGS AND OPERATING INSTRUCTIONS PRIOR TO USE.
2. USE ONLY ON HARD LEVEL SURFACE.
3. OVERLOADING RACK CAN CAUSE PRODUCT TO DAMAGE ITSELF OR PARTS AND OR CAUSE TIPPING, BENDING, DEFLECTION, MISUSE, DAMAGE TO PRODUCT OR OTHER ITEMS. DO NOT OVERLOAD PRODUCT PERSONAL INJURY AND/OR PROPERTY DAMAGE COULD OCCUR.
4. IT IS RECOMMENDED THAT 2 PERSONS ASSEMBLE PRODUCT.
5. NO ALTERATIONS SHALL BE MADE TO THIS PRODUCT.
6. ONLY ATTACHMENTS AND/OR ADAPTERS SUPPLIED BY THE MANUFACTURER SHALL BE USED.
7. FAILURE TO HEED THESE WARNINGS MAY RESULT IN PERSONAL INJURY AND/OR PROPERTY DAMAGE.

PRODUCT DESCRIPTION

The parts cart is ideal for temporary storage and transfer of parts. Features two adjustable shelves, four structural part brackets designed for hanging parts, four swivel casters and a unique outrigger slide-out stabilizer to help when storing or moving heavy parts.

ASSEMBLY INSTRUCTIONS

ASSEMBLY PARTS DIAGRAM IS ON PAGE 6.

1. ATTACH #2 TO THE BOTTOM OF #1.
ATTACH NON-LOCKING SWIVEL CASTERS TO ONE SIDE NARROW SIDE OF THE BOTTOM SHELF.
ATTACH LOCKING SWIVEL CASTERS TO THE OPPOSITE NARROW SIDE OF THE BOTTOM SHELF.
IMAGES (A TO I)



A

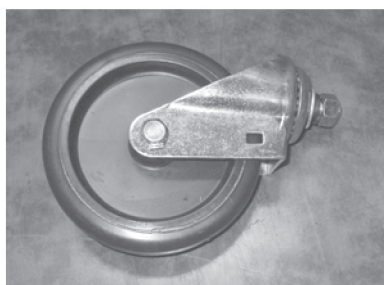

B

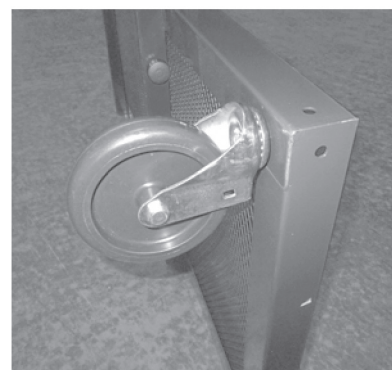

C

ASSEMBLY INSTRUCTIONS

1. CONT.



D

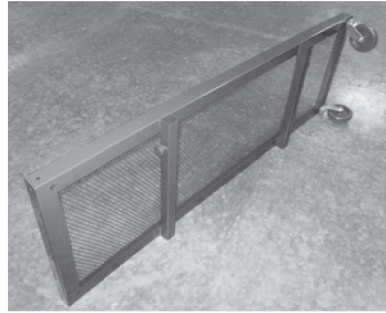

E

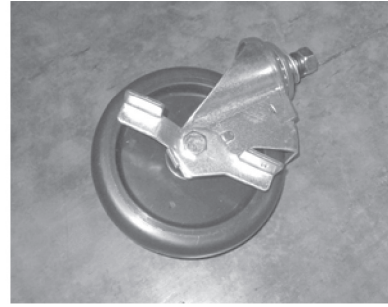

F



G



H



I

2. ATTACH #4 TO #1 AS SHOW IN IMAGE (J, K, L).

USE (qty-2 EACH ASSEMBLY) #5, 6, 7, 8 TO SECURE VERTICAL STRUCTURAL RAILS.

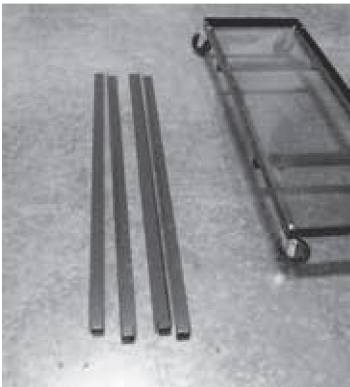

J



K



L

3. A. FIRST ATTACH #9 TO #4 PRESS DOWN FIRMLY AS SHOWN IN IMAGE (M).

B. NEXT ATTACH #10 TO #9 PRESS DOWN FIRMLY AS SHOWN IN IMAGE (M).

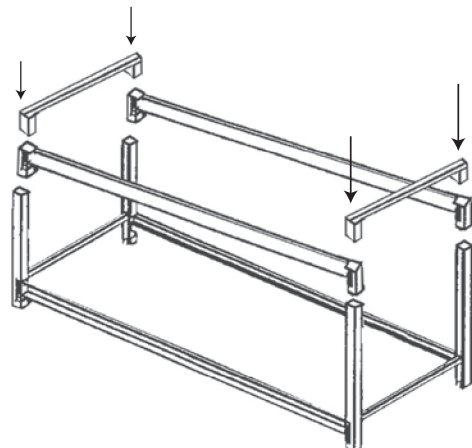

M

ASSEMBLY INSTRUCTIONS

4. ATTACH #11 TO #4 AS SHOW IN IMAGE (N, O, P).

USE (qty-8 EACH) #5, 6, 7, 8 TO SECURE THE CENTER SHELF AFTER YOU HAVE CHOSEN YOUR DESIGNATED HEIGHT CONFIGURATION.

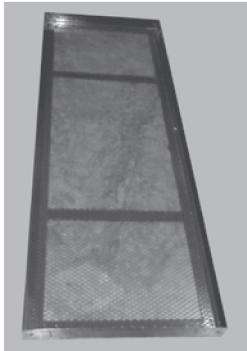

N

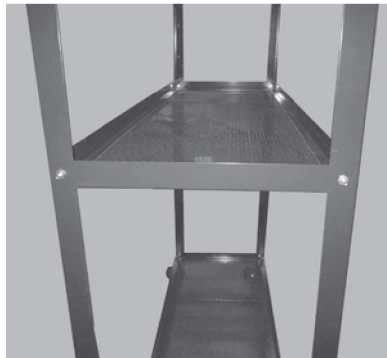

O



P

5. ATTACH #12 TO #4 STRUCTURAL RAILS AS SHOW IN IMAGE (Q, Q1, R).

USE (qty-1 EACH ASSEMBLY) #6, 7, 8 TO SECURE THE FLOATING SHELF BRACKETS. ADJUST BRACKETS AS NEEDED AFTER SHELF HAS BEEN ATTACHED IN NEXT STEP.

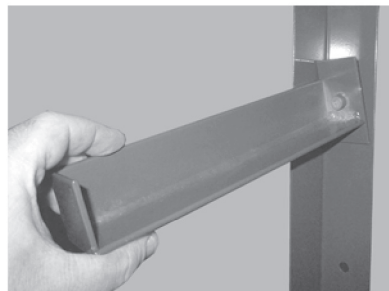

Q

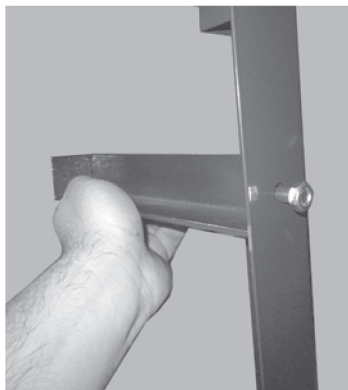

Q1

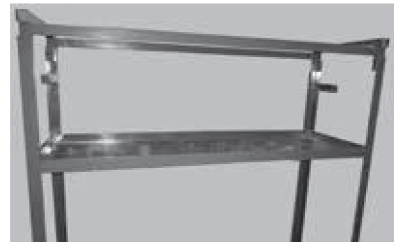

R

6. ATTACH #13 TO #12 SHELF BRACKETS. IMAGES (S, T, U, V)



S



T

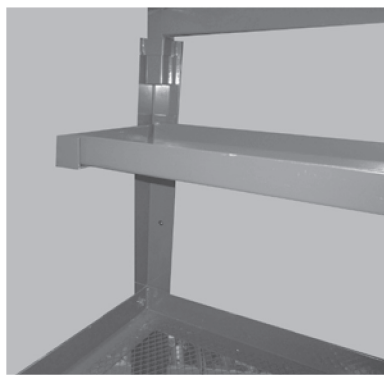

U

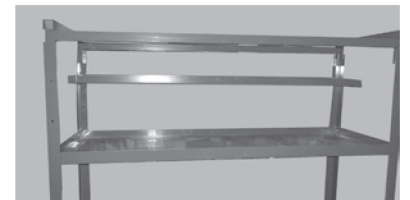

V

ASSEMBLY INSTRUCTIONS

7. ATTACH #14 TO #15 AUXILARY CASTER WHEEL ASSEMBLY. IMAGE (W, X)

ATTACH #16 TO #15 SLIDE OUT STABALIZER BAR

ONCE STABALIZER BAR IS ATTACHED TIGHTEN BOTH HANDLE KNOBS ON #15 TO SECURE. IMAGE (X, Y, Z)

ATTACH #15 TO #1 SLIDE OUT SUPPORT RAIL ASSEMBLY

ONCE SLIDE OUT SUPPORT RAIL ASSEMBLY HAS BEEN ATTACHED TIGHTEN BOTH HANDLE KNOBS UNDER #1 TO SECURE. IMAGE (Y, Z, AA)



W

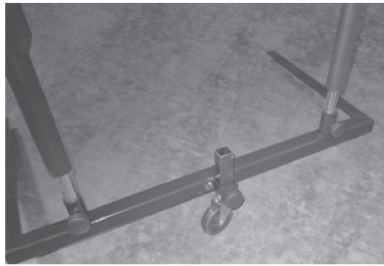

X



Y

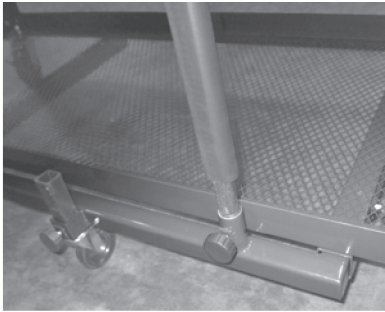

Z

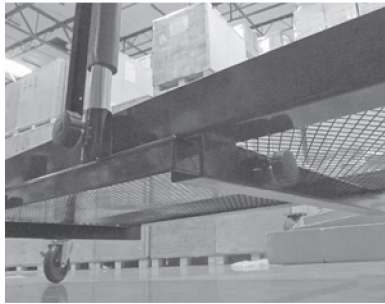

AA

8. COMPLETED UNIT. IMAGE (AB, AC).



AB



AC

WARRANTY

ONE YEAR LIMITED WARRANTY

For a period of one year from date of purchase, the manufacturer will repair or replace, at its option, without charge, any of its products which fail due to a defect in material or workmanship, or which fail to conform to any implied warranty not excluded hereby.

Performance of any obligation under this warranty may be obtained by returning the warranted product, including dated purchase receipt, to the retailer or distributor where the product was purchased.

For warranted service during the warranty period, the product must be returned to the retailer. Consumers should only submit product for repair directly to a warranty repair facility after the product warranty has expired. For the nearest approved Service Repair Facility, contact 1-888-448-6746, 8a.m. – 5p.m. PST, Monday – Friday.

ALL WARRANTY SERVICE DURING THE WARRANTY PERIOD MUST BE HANDLED DIRECTLY THROUGH THE RETAILER.

Except where such limitations and exclusions are specifically prohibited by applicable law, (1) the CONSUMER'S SOLE AND EXCLUSIVE REMEDY SHALL BE THE REPAIR OR REPLACEMENT OF DEFECTIVE PRODUCTS AS DESCRIBED ABOVE, and (2) THE MANUFACTURER SHALL NOT BE LIABLE FOR ANY CONSEQUENTIAL OR INCIDENTAL DAMAGE OR LOSS WHATSOEVER, and (3) THE DURATION OF ANY AND ALL EXPRESSED AND IMPLIED WARRANTIES, INCLUDING, WITHOUT LIMITATION, ANY WARRANTIES OF MERCHANTABILITY AND FITNESS FOR A PARTICULAR PURPOSE, IS LIMITED TO A PERIOD OF ONE YEAR FROM DATE OF PURCHASE.

This warranty gives you specific legal rights, and you may also have other rights which vary from state to state.

REPLACEMENT PARTS

For replacement parts, call our customer service department at 1-888-448-6746, 8 a.m. - 5 p.m., PST, Monday - Friday.

Not all components are replacement items but are illustrated as a convenient reference of location and position in the assembly sequence. When ordering parts, give model number, serial number and description.

PARTS LIST

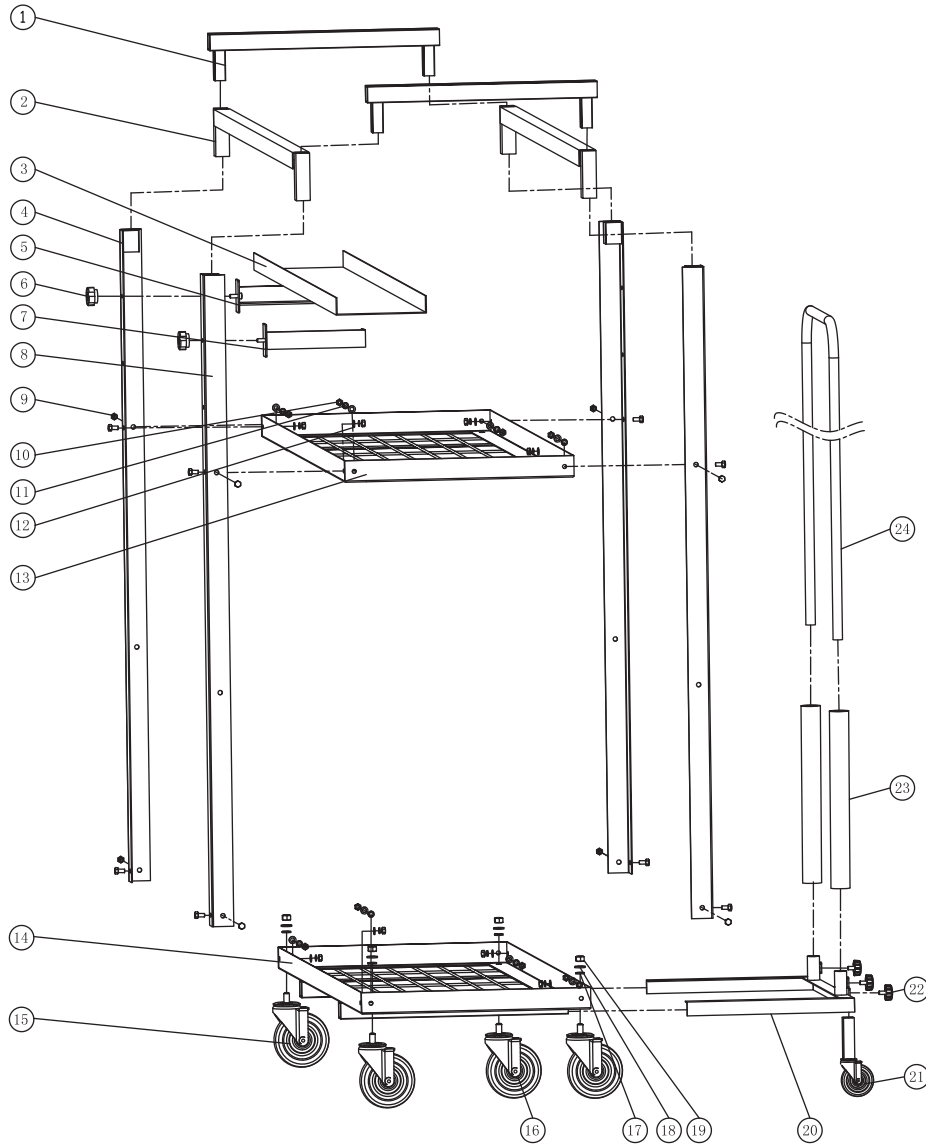

ITEM	DESCRIPTION	QTY	ITEM	DESCRIPTION	QTY
1	Short connecting assembly	2	13	Up grid box	1
2	Long connecting assembly	2	14	Down grid box	1
3	Cargo deck	1	15	5"caster	2
4	Left column assembly	2	16	5"caster with brakes	2
5	left baffle	1	17	Flat washer 12	4
6	Hand wheel	2	18	Spring washer 12	4
7	Right baffle assembly	1	19	Nut M12	4
8	Right column assembly	2	20	Slideway	1
9	Screw M8X20	16	21	Front wheel assembly	1
10	Nut M8	16	22	Set screw	5
11	Spring washer 8	16	23	Handle cover	2
12	Flat washer 8	16	24	Handle	1



TORIN JACKS, INC.
Ontario, CA 91761
Made in China

