

REPAIR PARTS LIST

ITEM.: TRQ05002

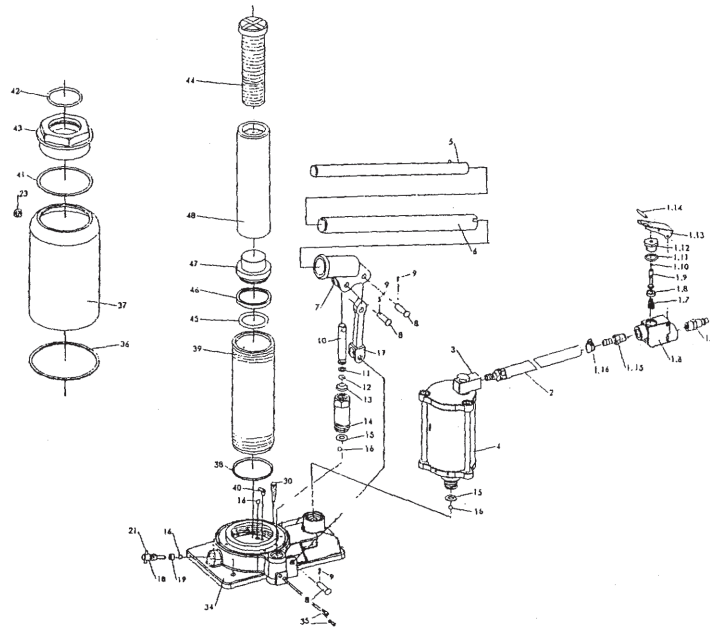

Air Bottle Jack

Operating Instruction & Parts Manual

Instructions for Use

NO	DESCRIPTION	QTY	NO	DESCRIPTION	QTY
1.3	hose connector	1	14	pump reservoir	1
1.6	valve body	1	15	copper washer	1
1.7	spring	1	16	steel ball	6
1.8	packing	1	17	plunger connecting rod	1
1.9	throttle	1	18	release valve screw	1
1.10	"O"ring 3X3.6	1	19	release valve seal	1
1.11	"O"ring 18X2.4	1	21	pin	1
1.12	nut	1	23	filler plug	1
1.13	lever	1	30	filter net	2
1.14	lever rin	1	34	base	1
1.15	hose connector	1	35	plug screw	4
1.16	hose band	2	36	cylinder bottom seal	1
2	air hose	1	37	reservoir	1
3	connector	1	38	packing	1
4	air pump	1	39	cylinder	1
5	handle upper	1	40	steel ball retaining	2
6	handle lower	1	41	cylinder top seal	1
7	plunger	1	42	"O"ring	1
8	shaft pin	3	43	top nut	1
9	cotter pin	3	44	extension screw	1
10	pump plunger	1	45	"O"ring	1
11	pump plunger retainer	1	46	"O"ring returner	1
12	"O"ring	1	47	ram header	1
13	dust proof ring	1	48	ram	1



FOR CUSTOMER SERVICE
PARA EL SERVICIO PARA EL
CONSUMIDOR
1-888-44-TORIN

TORIN JACKS, INC.
Ontario, CA 91761

MADE IN CHINA

Save these instructions. For your safety and the safety of others around you, read carefully before attempting to assemble, service or use your jack. Observe all safety and warning information. Always wear safety glasses when operating this product. Failure to comply with the information contained within could result in severe, even fatal injury and/or property damage.

PRODUCT DESCRIPTION

Air Actuated / Hydraulic Hand Jacks are designed for lifting, but not sustaining, loads ranging from up to 50 tons depending on the rated capacity of the jack. They can be used vertically or angled to 5 degrees from vertical position. After lifting, loads must be immediately supported by appropriate means. Each model is suitable for use in an appropriately rated and designed vertical or bench press structure. These jacks are not recommended for use in lifting or positioning houses and / or other building structures. For air actuated use, ensure that your air source can dedicate is recommended.

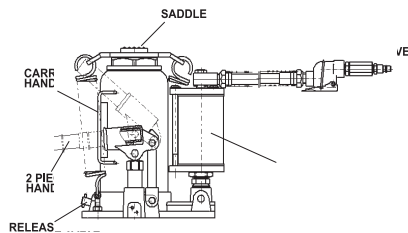

BEFORE USE

1. Verify that the product and the application are compatible, if in doubt call seller's telephone.
2. Before using this product, read the owner's manual completely and familiarize yourself thoroughly with the product and the hazards associated with its improper use.
3. Open the release valve (counter-clockwise no more than 2 full turns).
4. With ram fully retracted, locate and remove the oil filler plug. Insert the handle into the handle sleeve, then pump 6 to 8 strokes. This will help release any pressurized air which may be trapped within the reservoir. Ensure the oil level is just below the oil filler plug hole. Re-install the oil filler plug.
5. Pour a teaspoon of good quality, air tool lubricant into the air supply inlet of the lift control valve. (See Illustration) Connect to air supply and operate for 3 seconds to evenly distribute lubricant.
6. Check to ensure that jack rolls freely (if so equipped) and that the pump operates smoothly before putting into service. Replace worn or damaged parts and assemblies with seller's only.
7. This product is fitted to accept the popular 1/4" NPT air nipple. When installing 1/4" NPT nipple of your choice, ensure that thread tape or compound is used when servicing connections.
8. Inspect before each use. Do not use if bent, broken or cracked components are noted.

OPERATION

Lifting

1. Assemble 2 pc. handle, ensure that spring clips align with slots.
2. Secure the load to prevent inadvertent shifting and movement.
3. Position the jack near desired lift point.
4. Close the release valve by turning it clockwise until it is firmly closed.

CAUTION:

USE THE HANDLE PROVIDED WITH THIS PRODUCT OR AN AUTHORIZED REPLACEMENT HANDLE TO ENSURE PROPER RELEASE VALVE OPERATION. DO NOT USE AN EXTENDER ON THE AIR HOSE NOR THE OPERATING HANDLE WHEN USING TO LIFT VEHICLE, LIFT ONLY ON THE MANUFACTURER'S RECOMMENDED LIFT POINT AND IN ACCORDANCE WITH THE PUBLISHED GUIDELINES IN YOUR VEHICLE OWNERS MANUAL ALWAYS USE JACK STANDS TO SUPPORT THE LOAD IMMEDIATELY AFTER LIFTING.

5. Insert and secure handle into handle sleeve. Pump handle or squeeze the lift control valve until saddle contacts load. To end air operation, simply release the grip on the lift control valve. NEVER WIRE, CLAMP OR OTHERWISE DISABLE THE THE LIFT CONTROL VALVE TO FUNCTION BY ANY MEANS OTHER THAN BY USING THE OPERATOR'S HAND.
6. Raise load to desired height, then immediately transfer the load to appropriately-rated support devices such as jack stands.

▲ WARNING ▲

THIS IS A LIFTING DEVICE ONLY. IT IS DESIGNED TO LIFT PART OF THE TOTAL VEHICLE (ONE WHEEL OR AXLE). ALWAYS WEAR SAFETY GLASSES WHEN USING THIS EQUIPMENT. CENTER LOAD ON SADDLE BEFORE LIFTING. NEVER WORK ON , UNDER OR AROUND LOAD UNTIL IT IS PROPERLY SUPPORTED. TRANSFER THE LOAD IMMEDIATELY TO APPROPRIATE RATED JACK STANDS. DO NOT USE THIS PRODUCT FOR ANY PURPOSE OTHER THAN THAT FOR WHICH IT WAS INTENDED. IT IS OWNER'S RESPONSIBILITY TO KEEP LABELS AND INSTRUCTIONAL MATERIAL LEGIBLE AND AVAILABLE FROM THE MANUFACTURER. FAILURE TO HEED THESE AND ALL OTHER WARNINGS PERTAINING TO THIS PRODUCT CAN RESULT IN SUDDEN LOSS OF LIFTED LOAD RESULTING IN DEATH, PERSONAL INJURY OR PROPERTY DAMAGE.

Lowering

1. Raise load enough to carefully remove jack stands.
2. Insert handle release valve and slowly turn handle counterclockwise, but no more than 1/2 turn. If load fails to lower, carefully transfer the load to another lifting device and jack stands. Carefully remove affected jack, and then the jack stands. Lower the load, again by slowly turning the release valve no more than 1/2 turn.

▲ WARNING ▲

BE SURE ALL TOOLS AND PERSONNEL ARE CLEAR BEFORE LOWERING LOAD. DANGEROUS DYNAMIC SHOCK LOADS ARE CREATED BY QUICKLY OPENING AND CLOSING THE RELEASE VALVE AS THE LOAD IS BEING LOWERED. THE RESULTING OVERLOAD MAY CAUSE HYDRAULIC SYSTEM FAILURE WHICH COULD CAUSE SEVERE PERSONAL INJURY AND/OR PROPERTY DAMAGE.

3. After removing jack from under the load, push ram and handle sleeve down to reduce exposure to rust and contamination.

TROUBLESHOOTING

Symptom	Possible Causes	Corrective Action
Jack will not lift load	Release valve not tightly closed Overload condition Air supply inadequate	Ensure release valve tightly closed Remedy overload condition Ensure adequate air supply
Jack bleeds off after lift	Release valve not tightly closed Overload condition Hydraulic unit malfunction	Ensure release valve tightly closed Remedy overload condition Contact seller
Jack will not lower after unloading	Reservoir overfilled Linkages binding	Drain fluid to proper level Clean and lubricate moving parts
Poor lift performance	Fluid level low Air trapped in system	Drain fluid to fluid level With ram fully retracted, remove oil filler plug to let pressurized air escape. reinstall oil filler plug
Will not lift to full extension	Fluid level low	Ensure proper fluid level

MAINTENANCE

Important:

Use only a good grade hydraulic jack oil. Avoid mixing different types of fluid and NEVER use brake fluid, turbine oil, transmission fluid, motor oil or glycerin. Improper fluid can cause premature failure of the jack and the potential for sudden and immediate loss of load.

Adding oil

1. With saddle fully lowered and pump piston fully depressed, set jack in its upright, level position. Remove oil filler plug.
2. Fill until oil is level with the filler plug hole, reinstall oil filler plug.

Changing oil

For best performance and longest life, replace the complete fluid supply at least once per year.

1. With saddle fully lowered and pump piston fully depressed, remove the oil filler plug.
2. Lay the jack on its side and drain the fluid into a suitable container.

Note: Dispose of hydraulic fluid in accordance with local regulations.

3. Fill with good quality jack oil. Reinstall oil filler plug. We recommend Mobil D T E 13 or equivalent.

Lubrication

1. A coating of light lubricating oil to pivot points, axles and hinges will help to prevent rust and assure that wheels, casters and pump assemblies move freely.
2. Periodically check the pump piston and ram for signs of rust or corrosion. Clean as needed and wipe with an oily cloth. NEVER USE SANDPAPER OR ABRASIVE MATERIAL ON THESE SURFACES!
3. When not in use, store the jack with pump piston and ram fully retracted.