

# Torin® **BIG RED** JACKS

Operator's Manual

## **1000 lbs DOUBLE RAM TRANSMISSION JACK**

Models:  
TR4055



**WARNING :** Before using this appliance, read this Operator's Manual and follow all its Safety Rules and Operating Instructions.

- Safety
- Operation
- Maintenance

**SAVE THESE INSTRUCTIONS.** For your safety and the safety of others around you, read carefully before attempting to install, assemble, service or use this lifter. Observe all safety and warning information. Failure to comply with the information contained within could result in severe, even fatal injury and/or property damage.

## GENERAL DESCRIPTION

This outstanding transmission jack is one of a kind. Its two stage telescope provides fast and extra long lifting range and its saddle is adjustable to any height ranging from 34 1/4 in. (870mm) to 70 7/8 in. (1800mm). Its construction it's light in weight, agile and stable when placing the charge. It is ideal and optimal tool for assembling, disassembling, lifting and repairing motor parts in any garage shop.

## SAFETY INSTRUCTIONS

**WARNING!** Ensure all preliminary checks are carefully carried out before use of jack. Immediately repair or replace damaged parts (use authorised service agent). Ensure use of genuine parts only. Non authorised parts may be dangerous and will invalidate the warranty.

**WARNING!** Use jack on level and solid ground, preferably concrete. Ensure the floor over which the jack will be transported is swept clean.

- DANGER!** DO NOT use on asphalt, or any other soft surface as jack may sink or topple. Serious personal or fatal injury may result.

- DANGER!** If jack tips or leans **STOP WHAT YOU ARE DOING. MOVE QUICKLY TO A SAFE DISTANCE. DO NOT TRY TO HOLD OR STEADY JACK.** Serious personal or fatal injury may result.

- Use jack in an adequate working area for its function, keep area clean & tidy and free from unrelated materials. Ensure there is adequate lighting.

- Before use ensure the gearbox weight and size does not exceed the capacity of the jack.

- Ensure the vehicle is raised and stabilised at the correct height before attempting to move the jack under the vehicle.

- Keep all unauthorised persons away from the jack during lifting and lowering and when in transit.

- Maintain correct balance and footing. Ensure the floor is not slippery and wear non slip shoes.

- Remove ill fitting clothing. Remove ties, watches, rings, and other loose jewellery, and contain and/or tie back long hair.

**WARNING!** Ensure load is placed level and centrally on jack saddle and load is fixed in place before attempting to lift, lower, or transport.

- The lowering speed will vary according to the weight of the load and the release valve setting.

- Ensure the jack saddle is fully lowered and is clean, dry, and oil free before attempting to move the jack with or without a load.

- Diligence is required in ensuring that you continually monitor any operation until completed.

**WARNING!** DO NOT operate jack if any parts are damaged or missing.

- DO NOT exceed the rated capacity of the jack.

- DO NOT allow untrained persons to operate the jack.

- DO NOT place any part of your body within or under the jack during use.

- DO NOT raise or lower vehicle lifting platform whilst the transmission jack is being used.

- DO NOT transport the jack, with or without a load, with the saddle in the raised position.

- DO NOT get jack wet or use in damp or wet locations or areas where there is condensation.

- DO NOT operate the jack when you are tired, under the influence of alcohol, drugs or intoxicating medication.

- DO NOT lift or support vehicles with jack and do not use jack as a load sustaining device.
- DO NOT use jack for any purpose other than removal, transportation, installation of transmissions.
- DO NOT move jack without suitable restraint on the load.
- DO NOT make any modifications to the jack, and DO NOT adjust or tamper with safety valve.
- DO NOT remove any labels from the jack. If labels are damaged or unclear replace them.
- Use a qualified person to lubricate and maintain the jack.
- DO NOT use brake fluid to top up hydraulic unit. Use Sealay hydraulic oil only.
- Before storing in safe area, ensure all parts are clean, free of grease and oil (especially saddle). Lower saddle to the lowest position.

## ASSEMBLY INSTRUCTIONS

For easiest transportation the jack is not assembled at the time of purchase. Please refer to Picture No.1 and the instructions below to assemble your new transmission jack stand.

### Step 1 - The Base

- Attach the four ball bearing caster wheels to the 4 respective legs of the jack stand making sure to tighten the screw
- Connect the legs with the three bolts and screws provided.

### Step 2 - The Cylinder

- Loosen the three bolts on the base. Put the cylinder on the right position on the base of the stand and tighten the three bolts.
- Attach the two-haft circle handles to the cylinder with the 4 bolts and tighten them in place.

### Step 3 - The Saddle

- To insert the saddle in place before using please refer to Picture below. Tighten all bolts and nuts.

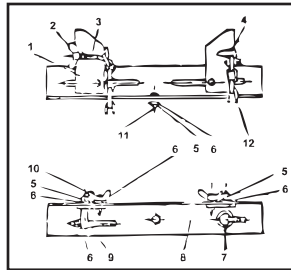

1. Connection
2. Butterfly nut
3. Chain hook
4. Chain clip
5. Nut
6. Washer
7. Collar Bolt
8. Corner Steel
9. Bolt
10. Butterfly bolt
11. Bolt
12. Chain

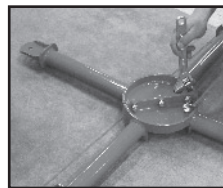

connect the legs with three bolts and screws provided, but do not make it tighten



attach the four ball bearing casters to the 4 respective legs of the jack, making sure to tighten the screws

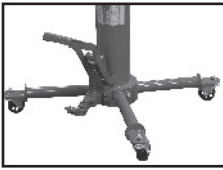

Put the cylinder on the right position on the base of the stand

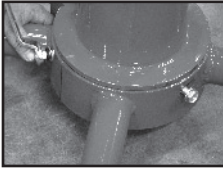

Tight the bolts on the side of the base



Tight the bolts under of the base

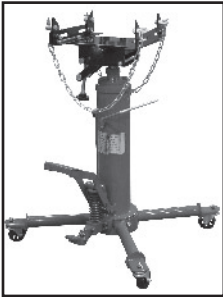

Assembly the handle to the cylinder, and inserts the saddle in place

and raised to allow the transmission jack to be positioned correctly.

- Ensure there are no other persons around or under the vehicle.
- Ensure saddle is in its lowest position and use handle to transport and centrally position jack beneath vehicle transmission.
- Pump the jack foot peddle and the saddle will rise.
- When saddle is just beneath the transmission re-adjust alignment if necessary to centralise the saddle.

#### LOWERING THE LOAD.

**WARNING!** Ensure the load is central and stable on the jack saddle and load is fixed in place before attempting to lift, lower, or transport. SLOWLY press the foot release valve knob to GENTLY lower saddle to the lowest minimum height before attempting to transport load.

#### TRANSPORTING THE LOAD.

**WARNING!** Ensure you have read, understood and apply **safety instructions**.

- Ensure the jack saddle is fully lowered and load is fixed in place before attempting to lift, lower, or transport.
- Transport the load over level and solid ground, preferably concrete, and ensure the floor is swept clean beforehand.
- Be diligent in continually monitoring the load in transit. Keep all other persons at a safe distance.
- **DANGER!** DO NOT use on asphalt, or any soft surface as jack may sink or topple. Serious personal or fatal injury may result.
- **DANGER!** If jack tips or leans STOP WHAT YOU ARE DOING. MOVE QUICKLY TO A SAFE DISTANCE. DO NOT TRY TO HOLD OR STEADY JACK.

Note this jack may be used with appropriate adaptors in order to handle such components as rear axle units and transfer cases that are within the weight limitations of the jack.

#### RE-INSTALLING A GEARBOX.

To transport, reposition beneath a vehicle, and raise a load up, reverse the procedures outlined above.

## OPERATING INSTRUCTIONS

The owner and/or operator is responsible for providing maintenance, maintaining all decals or warning labels and while in use, maintaining the unit in good work order. If the owner and/or operator is not fluent in English or French, the product warnings and instructions shall be read and discussed with the operator in the operator's native language by the purchaser/owner or his designee. Make sure that the operator comprehends its contents. Safety information shall be emphasized and understood prior to usage. The jack shall be inspected per the instruction manual prior to use.

It is the owner and/or operators responsibility to study all WARNINGS, operating, and maintenance instructions contained on the product label and instruction manual prior to operation of this unit. The owner/operators shall retain product instructions for future reference.

**WARNING!** Before use ensure you have read, understood and apply safety instructions.

**WARNING!** Ensure you prepare vehicle correctly before attempting to use the Transmission Jack.

#### POSITIONING JACK BENEATH LOAD.

Before use ensure the transmission weight and size does not exceed the capacity of the jack.

- Ensure the vehicle from which the gearbox is to be removed is correctly positioned, handbrake applied

## MAIN CONSTRUCTION

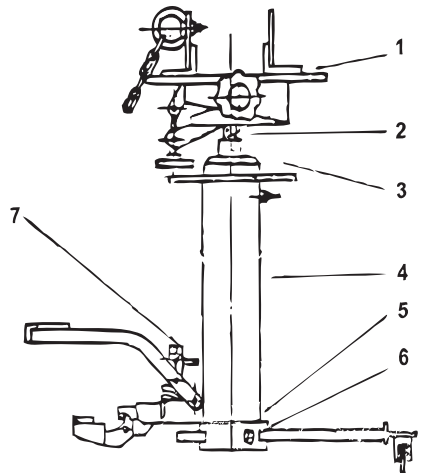

- |                       |          |         |
|-----------------------|----------|---------|
| 1. Saddle             | 2. 2#Ram | 3.1#Ram |
| 4. Cylinder           | 5. Base  | 6. Bolt |
| 7. foot operated pump |          |         |

## TROUBLE SHOOTING

PROBLEM	CAUSE	SOLUTION
Jack will not lift	No hydraulic oil, or defective suction valve or delivery valve Release valve is open	Contact authorised service agent. Close release valve.
Jack will only lift halfway	Hydraulic oil low, or excess of hydraulic oil	Contact authorised service agent.
Raised load will not hold	Defective valves, or defective piston packing	Contact authorised service agent.
Poor lifting	Defective plunger packing	Contact authorised service agent.

## MAINTENANCE

**IMPORTANT:** Only fully qualified personnel should attempt maintenance or repair.

- When the jack is not in use, the saddle must be in the lowest position to minimise ram and piston corrosion.
- Keep the jack clean and wipe off any oil or grease. Lubricate all moving parts with acid free oil.
- The oil cylinder is a sealed unit and must not be accessed. For service contact your authorised dealer.

**WARNING!** Only a good quality Jack oil must be used, DO NOT use brake fluid.

- Before each use, follow the pre-check list to ensure components are in good working order. If any suspect item is found remove jack from service and take necessary action to remedy the problem.
- DO NOT use the jack if you believe it has been subjected to an abnormal load or shock. If in doubt contact your local service agent.
- Periodically check the pump piston and piston rod for signs of corrosion. Clean exposed areas with a clean oiled cloth.

**IMPORTANT:** NO RESPONSIBILITY IS ACCEPTED FOR INCORRECT USE OF THE JACK.

Hydraulic products are only repaired by local service agents.

## WARRANTY

Torin Jacks, Inc. warrants its hydraulic jacks and tools for a period of one year against manufacturing and materials defects. Torin Jacks, Inc. will issue a one-for-one credit for all merchandise deemed defective due to manufacturing and or material defects. Torin Jacks, Inc. will not issue credit for customer abuse or misuse. Merchandise shall be deemed defective by letter from Torin Jacks, Inc. after inspection by Torin Jacks, Inc. or one of its representatives. Defective products shall be returned freight prepaid to Torin Jacks, Inc. by written authorization only. Some products may be authorized for field destruction, with return of handle assembly and saddle only.

## SPECIFICATION

Capacity	Minimum Lifting Height	Minimum Lifting Height	Net Weight
1000 lbs.	34-1/4"	70-7/8"	180.78 lbs

# EXPLODED PART LIST



**FOR AFTER SALE PARTS AND SERVICE:**

**Call 8 AM - 5 PM PST., Monday - Friday**

**1-888-448-6746**

**POUR OBTENIR DES PIÈCES DÉTACHÉES**

**ET UN SERVICE APRÈS VENTE :**

**Appelez entre 8:00 et 17:00 heure du Pacifique,  
du lundi au vendredi**

**1-888-448-6746**

**PARA VENTA DE PARTES Y SERVICIO:**

**Llame 8 AM - 5 PM Tiempo Pacifico., Lunes - Viernes**

**1-888-448-6746**

Copyright © 2007 Torin Jacks, Inc. All rights reserved.