



Operator's Instruction Manual Hydraulic Bottle Jack

MODEL #	Rated Capacity
T90203ST	4,000-lb
T90603ST	12,000-lb
T91203ST	24,000-lb



This is the Safety Alert Symbol. It is used to alert you to potential personal injury hazards. Obey all safety messages that follow this symbol to avoid possible injury or death. Read this Manual and follow all the Safety Rules and Operating Instructions before using this product.



Questions, problems, missing parts? Before returning to your retailer, call our customer service department at 1-888-448-6746, 8 a.m.- 5 p.m., PST, Monday-Friday.

Distributed by TORIN JACKS INC. Ontario, CA 91761

OWNER / USER RESPONSIBILITY



DO NOT OPERATE OR REPAIR THIS EQUIPMENT WITHOUT READING THIS MANUAL.

To maintain the Jack and User Safety, the responsibility of the owner is to read and follow these instructions. Follow all installation and operation instructions. Inspect the jack for proper operation and function. Read and follow the safety instructions. Keep Instructions readily available for equipment operators. Make certain all equipment operators are properly trained, understand how to safely and correctly operate the unit, and are properly trained. Allow unit operation only with all parts in place and operating safely. Use only genuine replacement parts. Service and maintain the unit only with authorized or approved replacement parts negligence will make the jack unsafe for use and void the warranty. Carefully inspect the unit on a regular basis and perform all maintenance as required. Store these instructions in the handle of your jack. Keep all decals on the unit clean and visible.

Warning Paragraph

Precautions and Safety should always be followed when Installing and Operating this lift. Store these instructions in the handle of your jack. Keep all decals on the unit clean and visible. Please be sure to make sure that ALL USERS read this manual before use and operation. Please read carefully the entire contents of this manual prior to installation and operation. By proceeding you agree that you fully understand and comprehend the full contents of this manual. Failure to operate this equipment as directed may cause injury or death. The manufacturer is not responsible for any damages or injury caused by improper use or neglect.

THIS IS A LIFTING DEVICE ONLY!

	
--	--

- This jack is designed only for lifting part of the total vehicle.
- Do not move or dolly the vehicle while on the jack.
- The vehicle must be supported after lifting immediately by appropriately rated jack stands.
- **NEVER** go under a vehicle that is not supported with appropriately rated jacks stands.

Always use Jack Stands!

DO NOT USE wood blocks or any other non-approved load sustaining devices. The manufacturer only permits loads to be sustained by jack stands that meet current ASME standards.

DO NOT USE wood blocks or any other non-approved lifting device in addition for a means of lifting with the jack and or load being raised. Failure to heed these warnings may cause injury or death

WARNING

Safety Markings

Safety markings shall conform to the ANSI Z535 series of standards.

- (a) Study, understand, and follow all instructions before operating this device.
- (b) Do not exceed rated capacity.
- (c) Use only on hard level surface.
- (d) Lifting device only. Immediately after lifting, support the vehicle with appropriate means.
- (e) Do not move or dolly the vehicle while on the jack.
- (f) Failure to heed these markings may result in personal injury and/or property damage.

Safety Messages

Additional safety messages include the following:

- (a) Lift only on areas of the vehicle as specified by the vehicle manufacturer.
- (b) No alterations shall be made to this product.

Additional Warnings

To avoid crushing and related injuries:

- Never work on, under or around a load supported only by hydraulic jack.
- Always use adequately rated jack stands.
- Chock each unlifted tire in both directions.
- Do not use this device to lift, level, lower, support nor move a house, mobile home, travel trailer, camper or any building structure.
- Be alert and sober when using this product. Do not operate under the influence of drugs or alcohol.





SAFETY INFORMATION

Study, understand and follow all instructions in this manual before operating the jack. Failure to heed these warnings may result in loss of load, damage to the jack and/or jack failure resulting in personal injury or property damage.

* **Position the Jack**

Position the jack to only lift on the areas of the vehicle as specified by the vehicle manufacturer.

* **Always Use Support Stands**

After lifting the vehicle always support the load with appropriately rated vehicle supports stands before working on the vehicle.

* **Do Not Overload Jack**

Do not overload this jack beyond its rated capacity. Overloading this jack beyond its rated capacity can cause damage to or failure of the jack.

* **Always Use on Hard Level Surfaces**

This jack is designed only for use on hard level surfaces capable of sustaining the load. Use on unstable or other insufficient surfaces can result in jack instability and possible loss of load.

* **Center Load on Jack Saddle**

Center load on jack saddle before lifting vehicle. Off-center loads and loads lifted when the jack is not level can cause loss of load or damage to the jack.

* **Do not raise or lower the vehicle unless tools, materials and people are clear.**

Clean up grease and oil spills immediately. When the lift is being lowered, make sure everyone is standing at least six feet away. Be sure there are no tools or equipment, left under the jack before lowering.

* **Always lower the jack slowly.**

* **DO NOT USE THE JACK TO SUPPORT OR STABILIZE A LOAD.**

Using the jack to support or stabilize a load may result in unexpected movement and result in serious injury, being crushed and death. Always securely chock and block (stabilize) the load to be lifted. Never place any part of the body under a raised load without properly chocking and supporting the load.

* **Never use the jack on curved or tubular vehicle bumpers, this will result in the vehicle slipping off the jack and falling, causing serious injury or death. Use a Bumper Lift to lift most vehicles with curved bumpers or plastic bumpers.**

* **Wear ANSI-approved safety glasses and heavy duty work gloves during use.**

* **Do not adjust the safety valve.**

* **Do not move or dolly vehicle while jack is in use.**

* **Stay alert. Use caution and common sense when operating jack.** Do not use a jack when tired, incoherent, dizzy, under the use or drugs or alcohol.

Training

- Read this manual before use. Do not allow anyone who has not read this manual, and/or does not understand the requirements, use the jack.

Spectators

- Do not allow bystanders around the jack or under the load supported only by the jack.
- Do not allow anyone in the vehicle while the jack is in use. Keep all spectators away from vehicle when in use.

Inspection

- Inspect the jack carefully before each use. Ensure the jack is not damaged, excessively worn, or missing parts.
- Do not use the jack unless it is properly lubricated.
- Using a jack that is not in good clean working condition or properly lubricated may cause serious injury.

Chock and Block (Stabilize)

- Apply parking brake in vehicle before operating jack.
- A chock is a wedge for steadying an object and holding it motionless, or for preventing the movement of a wheel. Chock the wheel opposite the end being lifted.
- When you block a load, you secure and support a load that is being lifted. The block(s) or stabilizer(s) should have a weight capacity that is greater than the weight of the load which is being lifted.

Additional Notes:

Save the receipt, warranty and these instructions.

It is important that you read the entire manual to become familiar with this product before you begin using it.

- **Do not modify** the jack in any way. Unauthorized modification may impair the function and/or safety and could affect the life of the equipment. There are specific applications for which the jack was designed.
- **Always check for damaged or worn** out parts before using the jack. Broken parts will affect the equipment operation. Replace or repair damaged or worn parts immediately.
- When jack is not in use, store it in a secure place out of the reach of children. Inspect it for good working condition prior to storage and before re-use.

MAINTENANCE INSTRUCTIONS

Important: Use only a quality grade hydraulic jack oil. Avoid mixing different types of fluid and NEVER use brake fluid, turbine oil, transmission fluid, motor oil or glycerin. Improper fluid can cause failure of the jack and the potential for sudden and immediate loss of load.

Adding oil

1. With saddle fully lowered, set jack in its upright, level position. Locate and remove oil filler plug.
2. Fill with oil even with the bottom of oil filler plug hole. Reinstall the oil filler plug.

Changing oil

For best performance and longest life, replace the complete fluid supply at least once per year.

1. With saddle fully lowered, remove the oil filler plug.
2. Lay the jack on its side and drain the fluid into a suitable container.

Note: Dispose of hydraulic fluid in accordance with local regulations.

3. Fill with oil even with the bottom of oil filler plug hole. Reinstall the oil filler plug.

Lubrication

A periodic coating of light lubricating oil to pivot points will help to ensure that pump piston linkages move freely.

Note: Never apply oil to the saddle. If saddle extension threads require lubrication; clean thread surfaces with a clean, dry cloth, then apply a drop of bearing grease to the threads. Distribute as evenly as possible along the threaded post.

Cleaning

Periodically check the pump piston and ram for signs of rust or corrosion. Clean as needed and wipe with an oily cloth.

Note: Never use sandpaper or abrasive material on these surfaces.

Storage

Store the jack with the pump piston, ram plunger, and saddle fully lowered. Ensure the release valve is open, but never more than ½ turn. This will help prevent rust and corrosion to those critical surfaces.

PREPARATION

Before use (refer to Fig 1)

1. Verify that the product and the application are compatible. If in doubt, contact Customer Support.
2. Before using this product, read the owner's manual completely and familiarize yourself thoroughly with the product and its components, and recognize the hazards associated with its use.
3. To familiarize yourself with basic operation, use the stamped end of the provided handle to engage and turn the release valve:
 - a. Clockwise until firm resistance is felt to further thread engagement. This is the 'CLOSED' release valve position used to raise the load.
 - b. Counterclockwise, but no more than ½ turn from the closed position. This is the 'OPEN' release valve position used to lower the load.
4. Check that the pump operates smoothly and that the extension screw will thread up/down easily before putting into service. Replace damaged or missing parts with factory authorized replacement parts only. Only the handle assembly, oil filler plug, label, and owners manual are available for this jack. Repair of this product may require special skills and knowledge and should only be attempted by a factory authorized service center.

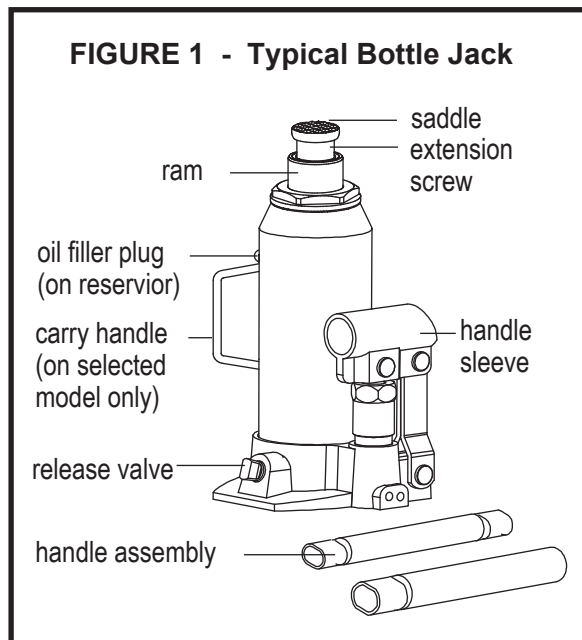

DESCRIPTION

The jack features an overlaid valve bypass system to prevent jack damage and user injury.

Specifications:

Compact Design allows use in confined spaces

MODEL #	Capacity	Lifting Range
T90230ST	2 Tons (4,000-lb.)	7 $\frac{1}{8}$ ~ 13 $\frac{5}{8}$ inches
T90603ST	6 Tons (12,000-lb.)	8 $\frac{1}{2}$ ~ 16 $\frac{1}{4}$ inches
T91203ST	12 Tons (24,000-lb.)	9 $\frac{1}{8}$ ~ 18 $\frac{1}{4}$ inches

WARNING: This Product contains chemicals known to the state of California to cause cancer and birth defects or other reproductive harm.

OPERATING INSTRUCTIONS



This is the safety alert symbol. It is used to alert you to potential personal injury hazards. Obey all safety messages that follow this symbol to avoid possible injury or death.

Lifting

1. Place vehicle in park with emergency brake on and wheels securely chocked to prevent inadvertent vehicle movement.
2. Locate and close release valve by turning handle clockwise until firm resistance is felt to further thread engagement. Center jack saddle under lift point.
3. Verify lift point, insert handle into handle sleeve and pump to contact lift point. To lift, pump handle until load reaches desired height.
4. Transfer the load immediately to a pair of appropriately rated jack stands.



Use only the handle assembly provided by the jack manufacturer. The handle assembly provided with this jack will safely engage the release valve and operate the handle sleeve. If the handle is worn, operates abnormally, or will not positively engage the release valve, STOP. Discontinue use of the jack until a factory replacement handle assembly can be acquired.

Lowering

1. Raise load high enough to clear the jack stands; then, carefully remove jack stands.
2. Slowly turn the handle counterclockwise, but no more than a ½ turn. If the load fails to lower:
 - a. Use another jack to raise the vehicle high enough to reinstall jack stands
 - b. Remove the affected jack and then the stands.
 - c. Using the other jack, lower the load by turning the operating handle counterclockwise, but no more than a ½ turn.
3. After removing jack from under the load, push saddle down to reduce ram exposure to rust and contamination.

TROUBLESHOOTING

JACK WILL NOT LIFT LOAD	JACK WILL NOT HOLD LOAD	JACK WILL NOT LOWER	POOR JACK LIFTING	CAUSES AND SOLUTIONS
X				Release valve is not completely closed. Turn handle clockwise.
X			X	Low oil level. Add oil as required.
X	X	X	X	Power unit malfunctioning. Replace the power unit.

PARTS LIST

Item Index No.	Description	Quantity
1	Saddle	1
2	Handle Sleeve	1
3	Handle Part	1
4	Release valve	1

* Picture only for reference.

Safe Operating Temperature is between
40°F – 105°F (4°C - 41°C)

The manufacturer reserves the rights to make design changes and or improvements to product lines and manuals without notice.

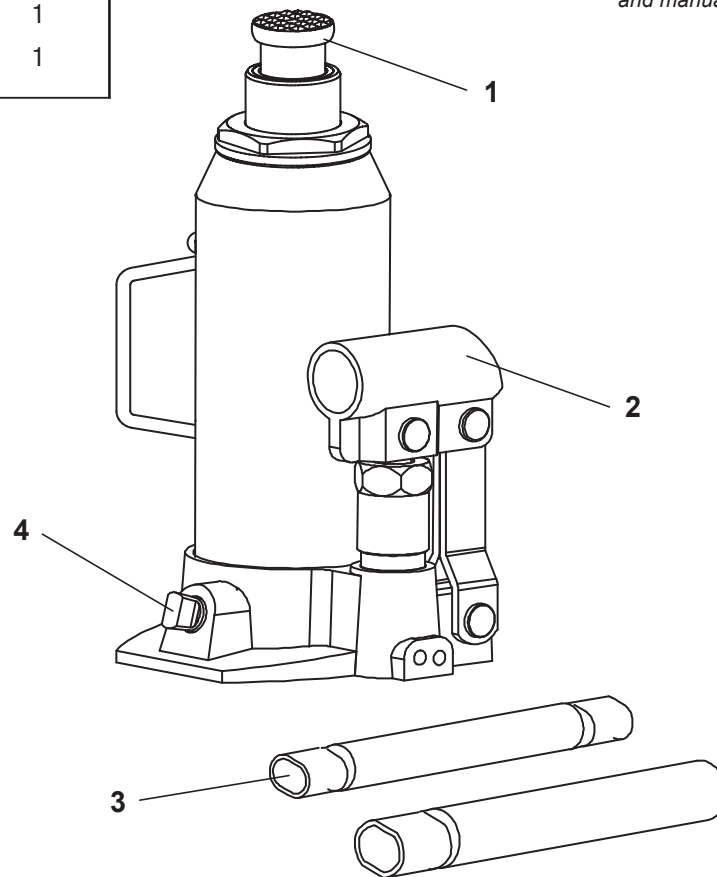

REPLACEMENT PARTS

For replacement parts Customer Service at 1-888-448-6746, 8 a.m. - 5 p.m., PST, Monday - Friday. Not all equipment components are available for replacement, illustrations provided are a convenient reference of location and position in the assembly sequence. When ordering parts the following will be required: Model Number, Serial Number and Description.



WARRANTY

ONE YEAR LIMITED WARRANTY

Torin® has been producing quality automotive repair and maintenance products since 1968. All products are sold are felt to be of the highest quality and are covered by the following warranty:

With proof of purchase for a period of one year from the date of that purchase, the manufacturer will repair or replace, at its discretion, without charge, any of its products or parts thereof which fail due to a defect in material or workmanship.

This warranty does not cover damage or defects caused by improper use, careless use or abuse of the equipment. This warranty does not cover parts normally considered to wear out or be consumed in the normal operation of the equipment.

Except where such limitations and exclusions are specifically prohibited by applicable law, (1) the CONSUMER'S SOLE AND EXCLUSIVE REMEDY SHALL BE THE REPAIR OR REPLACEMENT OF DEFECTIVE PRODUCTS AS DESCRIBED ABOVE, and (2) THE MANUFACTURER SHALL NOT BE LIABLE FOR ANY CONSEQUENTIAL OR INCIDENTAL DAMAGE OR LOSS WHATSOEVER, and (3) THE DURATION OF ANY AND ALL EXPRESSED AND IMPLIED WARRANTIES, INCLUDING, WITHOUT LIMITATION, ANY WARRANTIES OF MERCHANTABILITY AND FITNESS FOR A PARTICULAR PURPOSE, IS LIMITED TO A PERIOD OF ONE YEAR FROM DATE OF PURCHASE.

For any technical questions or warranty support please contact:

Torin® Customer Service directly by telephone at 1-888-44-TORIN (1-888-448-6746)

8:00am - 4:30 pm Pacific Time, Monday - Friday.

Alternately Customer Service can be reached through www.torinjacks.com or via email at info@torinjacks.com.

